

COOK-N-HOLD LOW TEMPERATURE SMOKER OVEN MODEL 1000-CH-SK-D SERIES

FEATURES AND BENEFITS:

- Fully insulated Cook-N-Hold smoker oven designed for flavorful results by slow cooking. Slow cooking means 15% to 20% less shrinkage.
- Smokes with real wood chips. Cold smoke fish and cheese as well with Kold Keepers.
- Efficient 3000 Watt power unit allows for reheating of prepared meals or bulk items. Maximum temperature 325° (163°C). Powerful 250 Watt cal rod heats chips quickly.
- Includes stainless steel vented chip box and variable one hour timer for mild to heavy smoke flavor.
- Standard solid state electronic control with large, clean, easy-to-read and operate LED digital display to ensure holding at precise food temperatures.
- Cook and hold over 120 lbs. (54 kg.) of meat in just 5 sq. ft. of floor space.
- Fully insulated, stainless steel interior and exterior for ease of cleaning. Smooth interior coved corners prevent food particle/grease buildup.
- Oven is operable on either 208 or 240 Volt circuits at the flip of a switch.
- Field reversible insulated door prevents temperature loss. Silicone door gasket for proper seal. High temperature ceramic magnetic latch for "easy open" and security during transport.
- Safety conscious anti-microbial latch protect against spreading germs. Standard with right hand hinges; left hand hinging available upon request.
- Removable stainless steel pan slides hold eight (8) 18" x 26" pans on 3" centers. Supplied with 3 wire grids.
- Heavy duty 5" casters, two swivel with brakes, two rigid. Provides mobility when fully loaded.
- Ovens can be stacked for flexibility.
- Cres Cor recommends soaking wood chips for a minimum of 24 hours before usage.

Deluxe Models (-DX) have 18 factory or field programmed cook & hold cycles. Each programmed menu can be customized for exact time and temperature needs. Probe cooking includes one 6" meat temperature probe and port.

POWER UNIT OPTIONS:

3000 Watts, 208/240 Volts, 1 Phase, 60 Hz.
3000 Watts, 208/240 Volts, 3 Phase, 60 Hz.



1000-CH-SK-DE



All Ovens come standard with easy-to-read and operate LED digital controls.



Deluxe Controls are available with 18 programmable menus and 6" meat probe.

ACCESSORIES and OPTIONS (Available at extra cost):

- Deluxe version with 18 programmable menus and 6" meat probe (or optional 3" food probe).
- Kold Keeper
- Stacking Kit
- Tempered Glass Door Window
- Key Lock Latch
- Extra Wire Grids
- Perimeter Bumper
- Corner Bumpers
- Various Caster Options
- 120 Volt Service
- Mobile Equipment Stand 24"

See page E-10 for accessory details.



1000-CH-SK-D SERIES

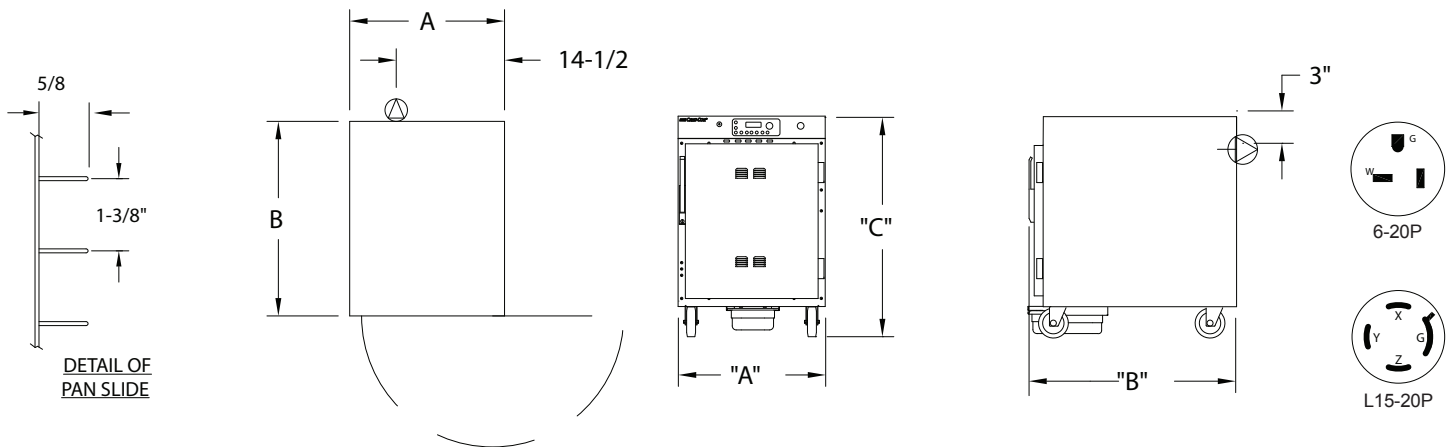

CRES COR MODEL NO.	PAN			DIM "A"	DIM "B"	DIM "C"	INSIDE CLEAR DIMENSIONS*			WEIGHT ACT.	
	CAP	SIZE		WIDTH	DEPTH	HEIGHT	WIDTH	DEPTH	HEIGHT		
1000-CH-SK-DE 1000-CH-SK-DX	8	18 X 26	IN	22-5/8	32-3/4	42	18-3/16	27	25	LBS	215
		460 X 660	MM	575	835	1070	465	690	635	KG	98
1000-CH-SK-STK-DE 1000-CH-SK-STK-DX	16	18 X 26	IN	22-5/8	32-3/4	77	18-3/16	27	25	LBS	430
		460 X 660	MM	575	835	1960	465	690	635	KG	195

*Inside dimensions for each compartment

CABINET:

- Body: 22 ga. stainless steel outer body.
- Inner body: 18 ga. stainless steel.
- Reinforcement: Internal framework of 18 ga. stainless steel.
- Insulation: Fiberglass, thermal conductivity (K factor) is .23 at 75°F, 1-1/2" in walls, 1" in doors.
- Drip pan: 18 ga. stainless steel with drain; removable.
- Wood chip box (removable): 18 ga. stainless steel; 3-5/8" L x 8" W x 2-1/4" H with 8" long handle; mounts on lower rear wall.
- Casters: 5" dia., modulus tires, 1-1/4 wide, load cap. 250 lbs. each, temp. range -45°/+180°F. Delrin bearings. Front swivel casters equipped with brakes; rigid casters on rear.

DOOR:

- Field reversible.
- Formed 20 ga. stainless steel.
- Latch: Anti-microbial chrome plated zinc with composite handle, ceramic magnetic type; mounted inboard.
- Hinges (2): Heavy duty chrome plated zinc; mounted inboard
- Gaskets: Perimeter type, silicone.
- Adjustable vents.

PAN SLIDES (removable):

- 18 ga. stainless steel angles, 1 x 1-3/8; riveted on 3" centers.
- Grids: Stainless steel, 18 x 26; supplied with (3) grids.

CLEARANCE REQUIREMENTS:

- 3" (76mm) at the back, 2" (51mm) at the top, 1" (25mm) at both sides.

POWER REQUIREMENTS:

- 3000/2650 Watts, 208/240 Volts, 60 Hz., 1 phase, 20 Amp. Service 14 Amps at 208 Volts, 13 Amps at 240 Volts.
- 3000/2650 Watts, 208/240 Volts, 60 Hz., 3 phase, 20 Amp. Service 8 Amps at 208 Volts, 7 Amps at 240 Volts.

ELECTRICAL COMPARTMENT:

- Control panel: Formed stainless steel; black front.
- Thermostats (cook/hold): Solid state digital display control, 140°F (60°C) to 325°F (163°C).
- Switch: ON-OFF push button type.
- Power Cord: Permanent, 6 ft. 12/3 ga. with right angle plug.
- Three (3) heater circuits.
- One hour smoker timer with power light.
- Thermometer: Digital display.
- Voltage selector switch: Change to 208 or 240 Volt; on back of oven.

INSTALLATION REQUIREMENTS:

- This model complies with section 59 of UL710B for emissions of grease laden air, and according to UL is not required to be placed under a ventilation hood. Check local requirements before installation.

SHORT FORM SPECIFICATIONS

Cres Cor Insulated Smoker Oven Model 1000-CH-SK-____-D_; Solid state electronic controlled times and temperatures. Outer body of 22 ga. stainless steel; inner body and frame of 18 ga. stainless steel. Fiberglass insulation 1-1/2" in walls; 1" in door. Stainless steel internal frame; coved corners. Anti-microbial chrome plated latch. Three (3) heated inner walls. Smoker box and timer. Removable pan supports for (8) 18" x 26" pans spaced on 3" centers. Casters 5" modulus casters (2) swivel, (2) rigid, Delrin bearings. Load capacity 250 lbs. each. 2-Year Parts / 1-Year Labor warranty. Lifetime on heating elements (excluding labor). Provide the following accessories: _____ CSA Sanitation and safety certified US & CAN.



5925 Heisley Road • Mentor, OH 44060-1833
Phone: 877/CRESCOR • Fax: 440/350-7267
www.crescor.com

© Crescent Metal Products, Inc. 2015 All rights reserved.

In line with its policy to continually improve its products, CRES COR reserves the right to change materials and specifications without notice.

Litho in U.S.A.